

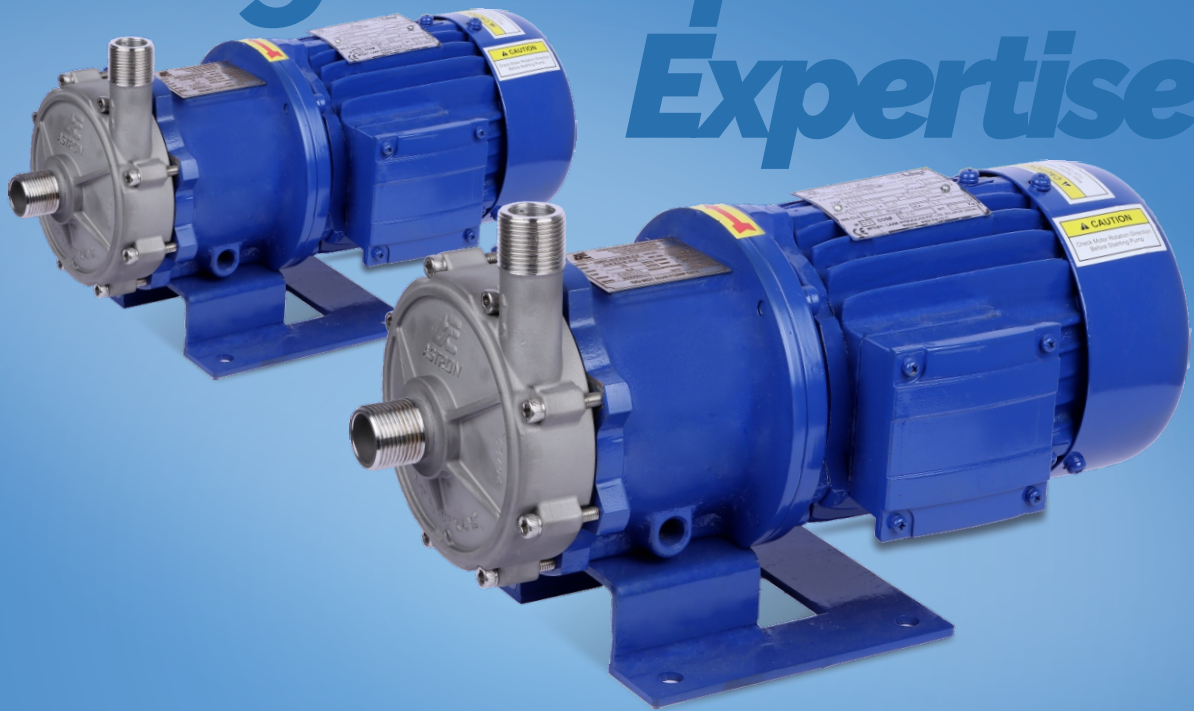

*Recognized for  
Expertise*



## Magnetic Drive Compact Pump (MDCP)



Product Catalogue  
[www.astronpumpsindia.com](http://www.astronpumpsindia.com)



## WHY CHOOSE US ?

One of our ethics is to only sell a quality product that is proven and that we believe in. We're certainly not only a pump manufacturing company out there, but we effort to be the best. We based our service on a foundation of skills, expertise, and experience in a cost-effective manner.



**Astron Pumps & Equipments Pvt. Ltd.** is a magnificent company that produces numerous types of centrifugal pumps as well as spare parts in the highest quality.

Now, in the market, we have introduced a new product whose motor and pump are close coupled in a convenient and compact design for quick installation in limited space.

## FEATURES :

- Specific magnets were used for long-lasting pumps.
- Pumps manufactured in accordance with DIN/EN/ISO performance standards.
- Superior silicone grease must be used to prevent stuck incidents between all mating parts.
- Designed to protect against overloading.
- Quick disassemble and reassemble

## BENEFITS :

- It has been designed to be compact in order to take up less space.
- The level of vibration and noise should be negligible.
- Magnet power provides precise efficiency with minimal slippage.
- During the dispatch process, least manpower was used.
- All rotating components are connected by a common shaft.

## APPLICATIONS :

- Alkali and caustic chemical pumping.
- For use in the industrial, firefighting, and building construction industries.
- Oils for heat transfer
- Fluid circulation of radioactive, toxic, and acidic liquids.
- Recycling and waste management



### SPECIFICATIONS :

Flow upto	:	max. 165 lpm or max. 43.7 US gpm
Head upto	:	max. 19 m or 62 ft
Max. Motor power	:	0.75 kW or 1 HP
Magnets	:	Ferrite/Rare Earth/Specially Designed
Temperature Range	:	-35°C to +200°C
Impeller Type	:	Semi Open
Drive	:	Close Couple
Flange Type	:	Threaded BSP
Material Grade	:	SS304, SS316, SS316L, Hastelloy, Cast Iron and Duplex.

### TECHNICAL DATA TABLE :

PUMP MODEL	BORE		MAX CAPACITY l/min	MAX HEAD m	MOTOR kW/HP	PUMP WEIGHT kg
	SUCTION	DISCHARGE				
	mm	mm				
MDCP-3/4" X 3/4"- 4"	20	20	102	10	0.37/0.5	18
MDCP-3/4" X 3/4"- 4.5"	20	20	125	13.5	0.55/0.75	20
MDCP-1" X 3/4"- 5"	25	20	165	19	0.75/1	31

### GENERAL ASSEMBLY DRAWING:

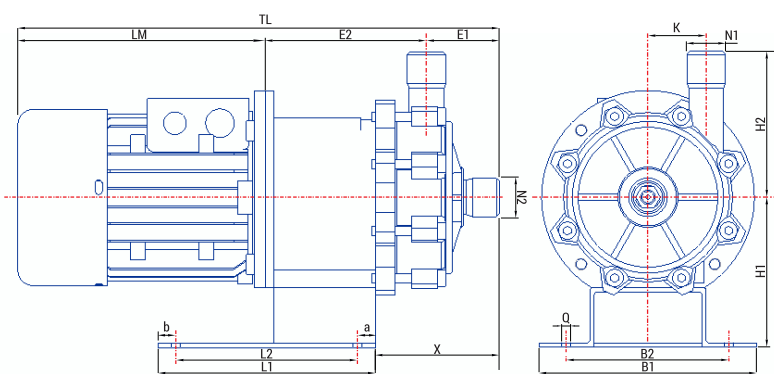

### PERFORMANCE CHART :

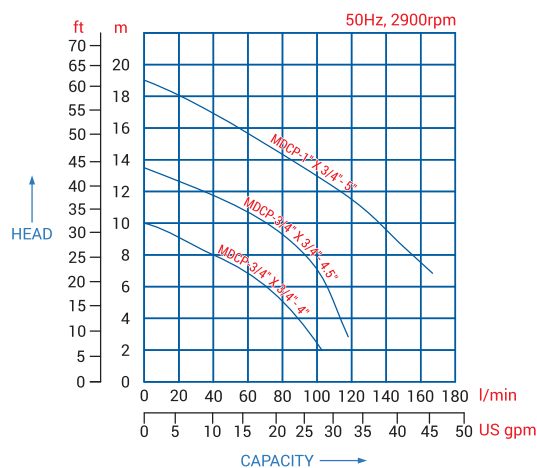

### DIMENSION TABLE : (All dimensions are in mm)

PUMP MODEL	E1	E2	H1	H2	LM	TL	X	K	L1	L2	a	b	B1	B1	Q	N1	N2
MDCP - 3/4" X 3/4"- 4"	50	112	100	100	210	372	77	40	150	118	16	16	150	120	10X4 NOS.	R-3/4" BSP	R-3/4" BSP
MDCP - 3/4" X 3/4"- 4.5"	50	112	100	100	210	372	77	50	150	118	16	16	150	120	10X4 NOS.	R-3/4" BSP	R-3/4" BSP
MDCP - 1" X 3/4"- 5"	60	113	100	100	230	403	87	45	150	118	16	16	150	120	10X4 NOS.	R-3/4" BSP	R-1" BSP

## MDCP MODEL :

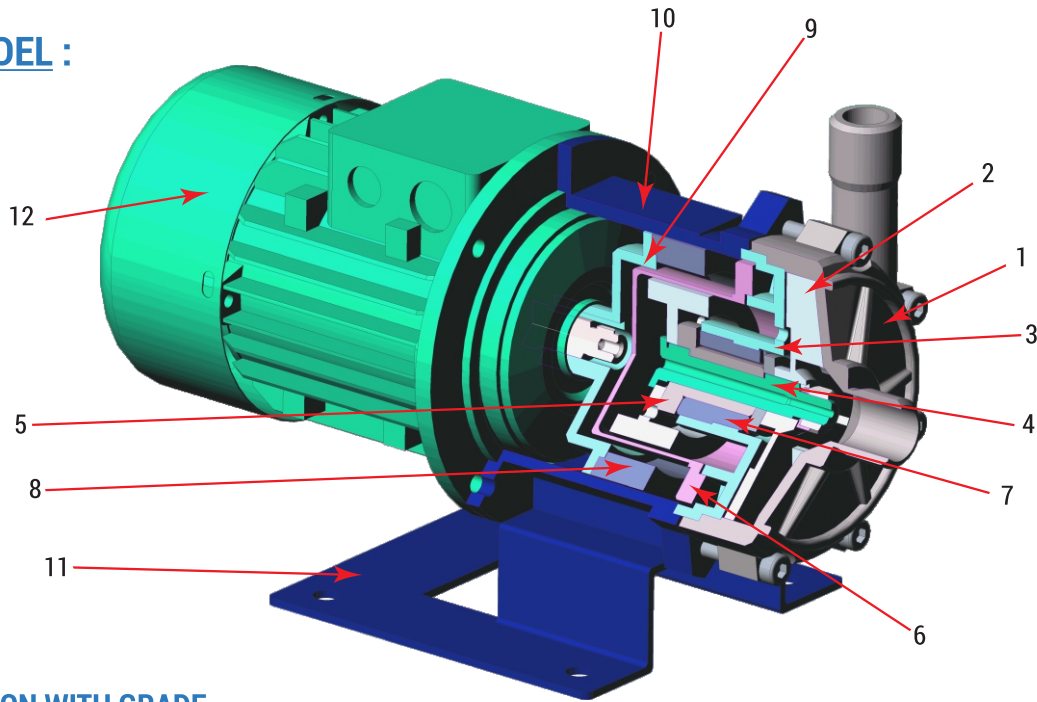

## CONSTRUCTION WITH GRADE

PART NO.	DESCRIPTION	GRADE
1	Casing	SS304 / SS304L / SS316 / SS316L DUPLEX ALLOY / HASTELLOY
2	Impeller	
3	Casing Cover	
4	Shaft	SS304 / SS316 / SS316L
5	Bearing Bush	METALLIC CAR / SIC / TC
6	Can	SS316L / HAST-C
7	Inner Magnet Assembly	FERRITE & SPECIAL MAGNET
8	Outer Magnet	FERRITE & SPECIAL MAGNET
9	Magnet Carrier	CI / WPS
10	Adapter	CI / WPS
11	Base Frame	MS
12	Flameproof & Non-flameproof Motor	AS PER REQUIREMENT
	Gasket	PTFE / CFT
	Fasteners	SS304 / SS316 / SS316L

## ASTRON PUMPS AND EQUIPMENTS PVT. LTD.

### OFFICE & MFG. UNIT

Plot No. B/173/3, Nr. Sonal Park, State Highway-41, Palanpur,  
Dist-Banaskantha, Kanodar-385520, Gujarat. INDIA  
Tel. +91-9601584988 / +91-9601584989

### MUMBAI OFFICE

1A, 1<sup>st</sup> Floor, Sadhana Industrial Estate, Oshiwara,  
S.V.Road, Jogeshwari (w), Mumbai-400102.  
Tel. +91-98194 44235 / +91-98332 94369

### E-MAIL

info@astronpumpsindia.com  
sales@astronpumpsindia.com



Scan to download PDF

AUTHORISED DEALER / DISTRIBUTOR